



FEATURES

- Single stage, direct-driven
- Air-cooled, no water required
- Simple installation
- Low noise levels
- Compact design
- Integral exhaust filter, oil free discharge air
- Includes pressure gauge and gas ballast

APPLICATIONS

- Meat packaging
- Food processing
- Thermoforming
- Composites
- Medical
- Laboratory
- Vacuum cooling
- Robotics
- Degassing
- Autoclaves

OPTIONAL ACCESSORIES

- Pre-Assembled Vacuum Kit Available (KVRXA-63 & KVRXA-100): Includes all plumbing, filtration, check-valves, regulating valves, and gauges required for quick installation and easy maintenance.

RXA-63/100

PERFORMANCE (60HZ)

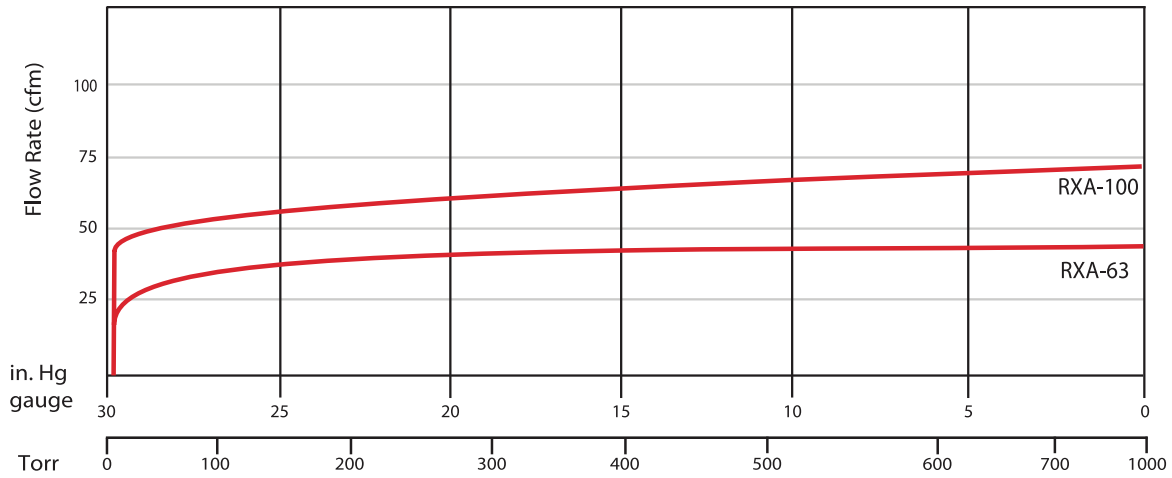

Model	Phase	Displacement (cfm)	Ultimate Continuous Vacuum (inHg/Torr)	Motor Output	Motor Speed (RPM)	Voltage (V)	FLA	Noise Level (dBA)	Approx. Weight (lb)	Oil Capacity (L)
RXA-63	3	44	29.91/0.075	3.0	1800	230/460	7.8/3.9	68	141	2.5
RXA-63-SP	1	44	29.91/0.075	3.0	1800	115/208-230	25.1/13.9-12.5	68	141	2.5
RXA-100	3	71	29.91/0.075	5.0	1800	230/460	12.4/6.2	68	165	2.7

All measurements are ±10%. Standard motor is Class 1 Div 2.

APPROXIMATE DIMENSIONS

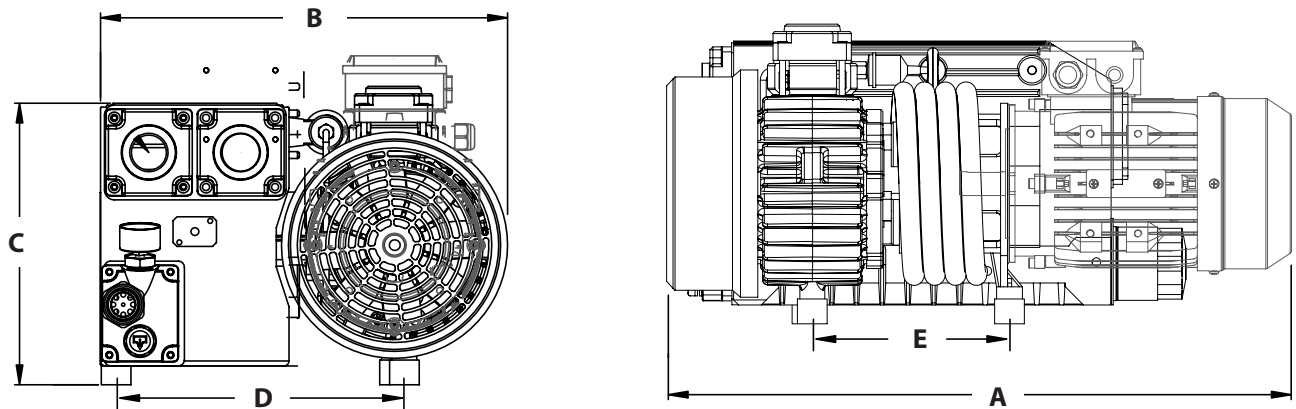

Model	A	B	C	D	E	Inlet/Outlet
RXA-63	25.4"	16.2"	11.9"	11.5"	7.4"	1.25" NPT
RXA-63-SP	25.4"	16.2"	11.9"	11.5"	7.4"	1.25" NPT
RXA-100	27.7"	16.2"	11.9"	11.5"	8.8"	1.25" NPT

Please contact the factory for precise dimensions.

CONTACT

