





# **Installation Guide Standard Air Knife**

**1500 CPM ALL SIDE**



# Tool Requirements

Can System: up to 1500 cpm		
<i>Component</i>	<i>Tools Description</i>	<i>Image</i>
Buna Sleeves	-English Wrench Set	
Hose Clamps	-Flat Head Screwdriver	
Flex Hose	-Tin Snips	
Air Knife Support Brackets	-English Allen Wrench Set -English Wrench Set -Drill -17/64in drill bit -Tap Handle -5/16-18in tap	



# Air Knife Installation Assembly Overview

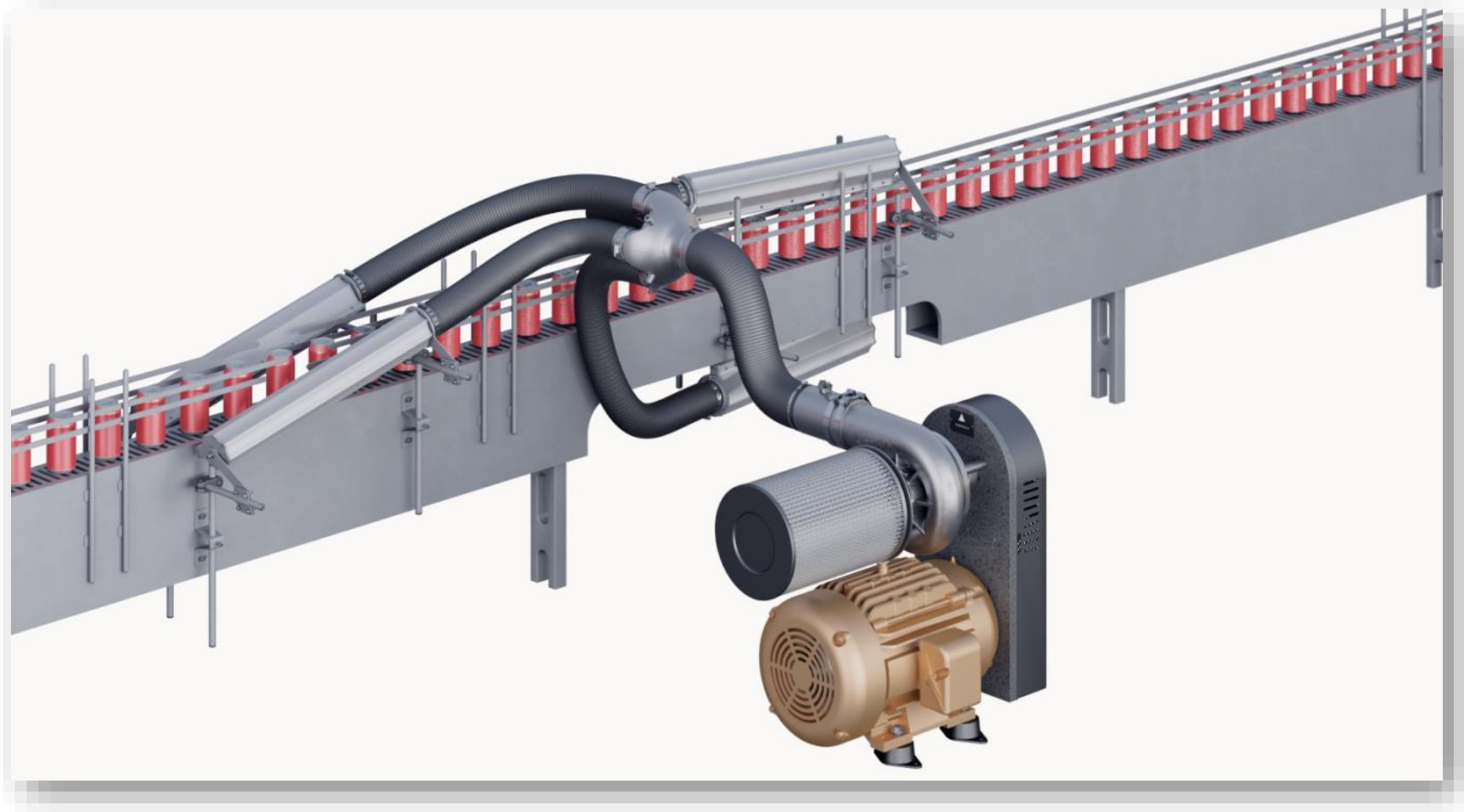



# Air Knife Installation Assembly Overview

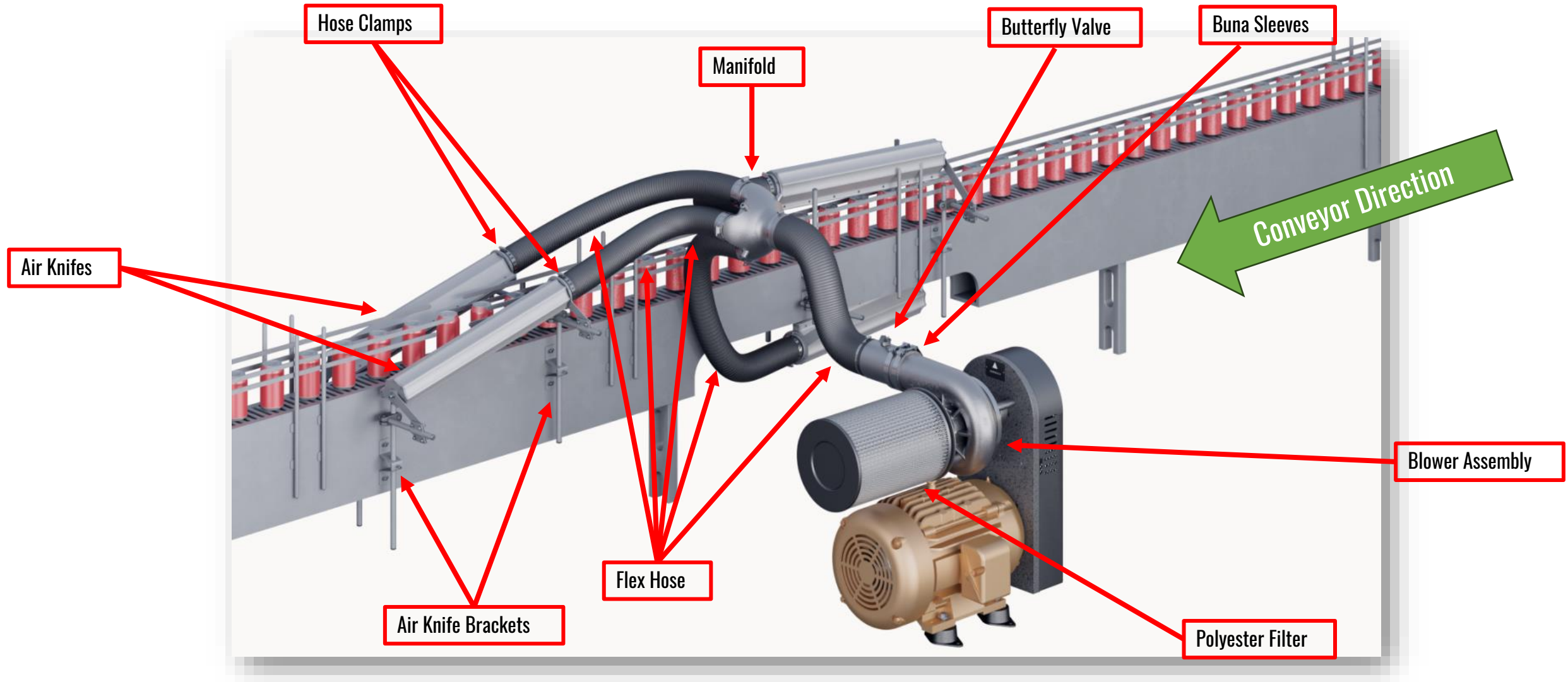



# Air Knife Bracket Assembly

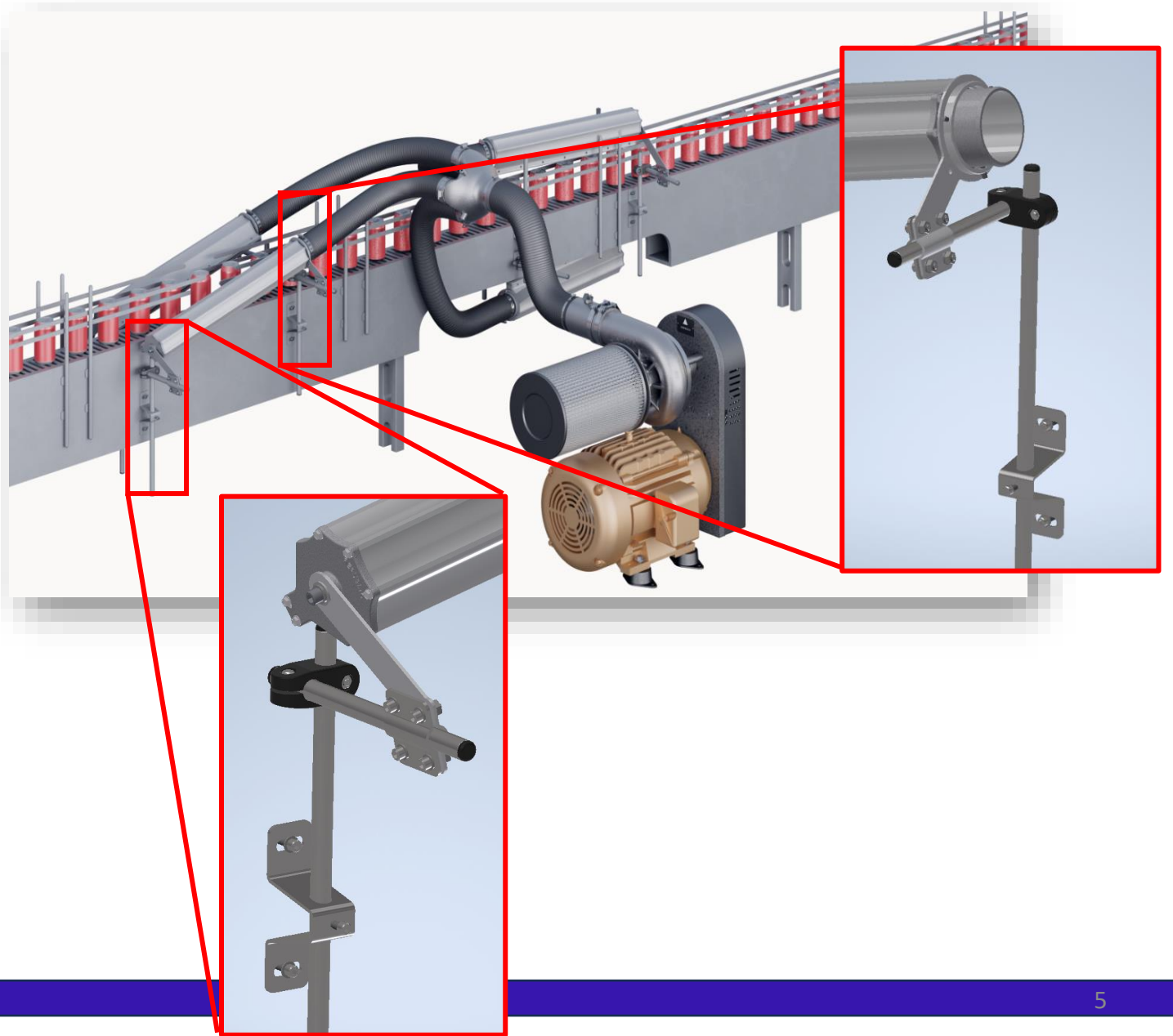



# Air Knife Bracket Assembly

Utilizing provided materials, assemble the Air Knife support brackets as shown in the **images 1-5**.

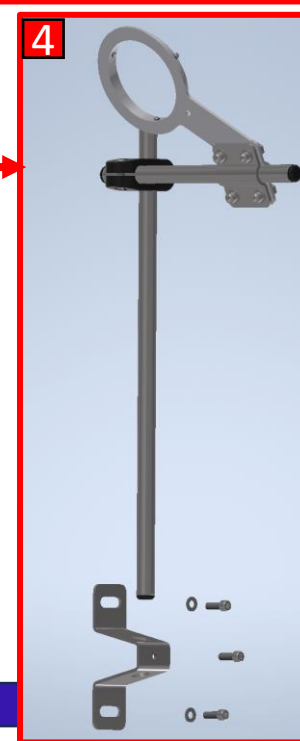
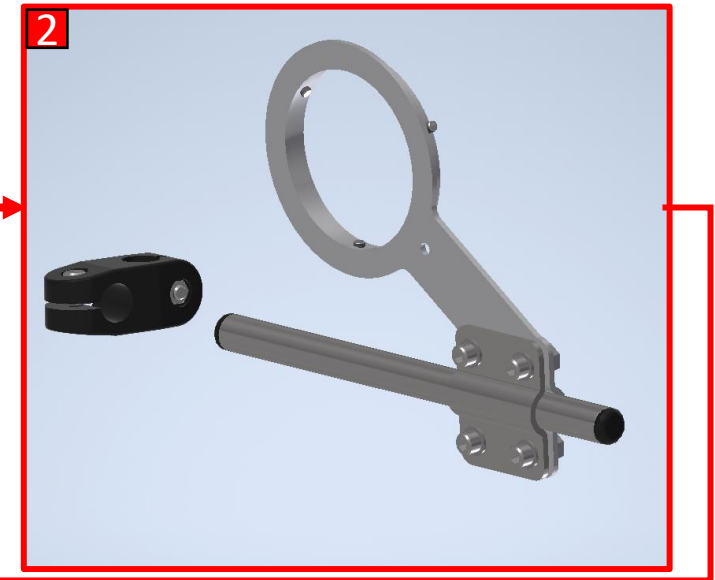
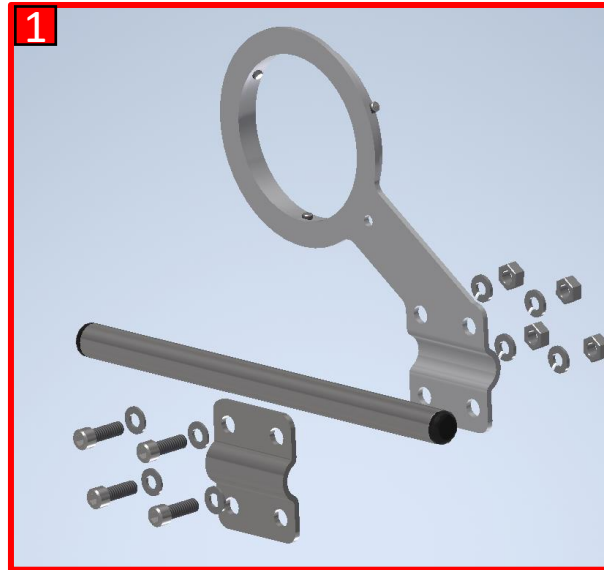



# Air Knife Bracket Assembly

After completion of the assembly step from **image 6** repeat the same assembly process as showing in **images 2-4** on the previous page.

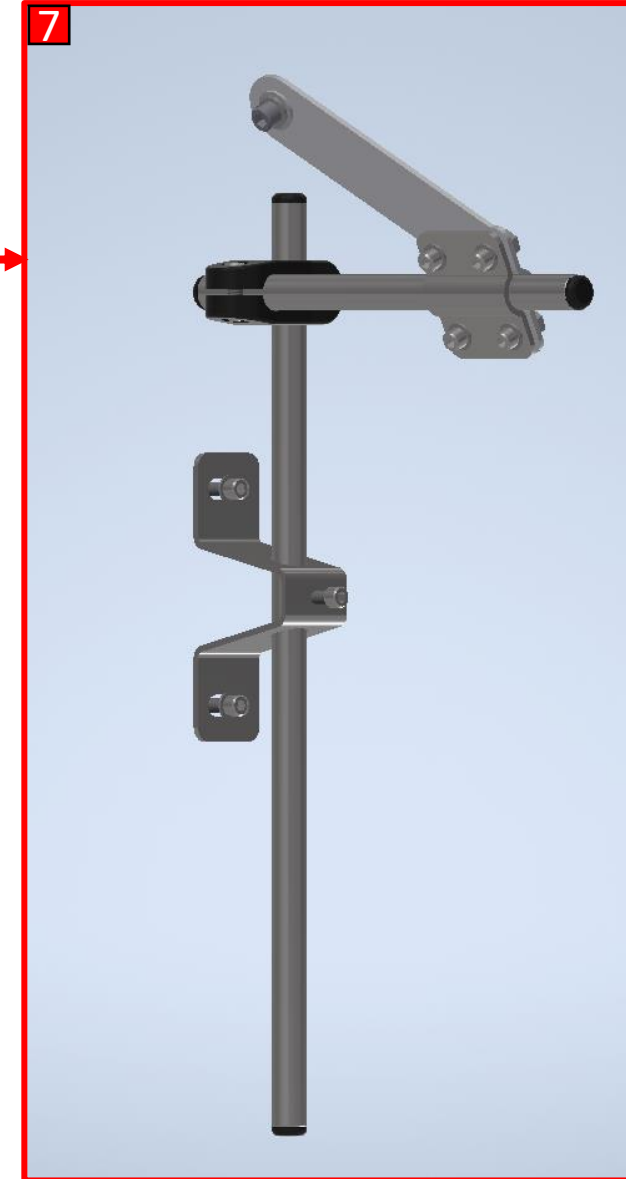
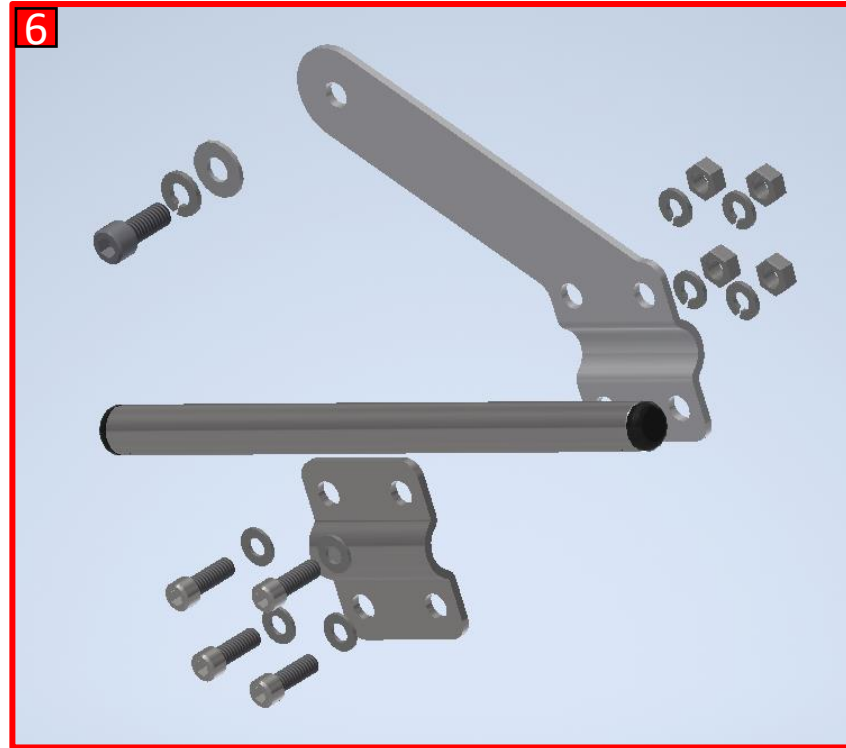





# Air Knife Locations

- 1.) Identify desired Air Knife location on conveyor
- 2.) Assembly mounting brackets onto Air Knife systems
- 3.) Mount Air Knife system with assembled brackets onto conveyor

\*Mount air knives as close to the product as possible. All conveyor guide rails must be cut to accommodate the air knife slot. There must be no interruption in the air flow between the air knife slot and the product to be dried. 1/4" to 1/2" is the optimum distance at which the air knives should be installed from the product to be dried.

\*Do not adjust the air knife gap without consulting Republic Manufacturing or our local representative. Increasing the flow will increase the motor amp draw and may damage the motor.

\*Install the complete system in such a manner that the air knives do not spray water/liquid onto the blower, motor or inlet filter. This will reduce the life of the blower and motor and may lead to re-contamination of the dried product. A blower enclosure may be required. Contact Republic Manufacturing for information.

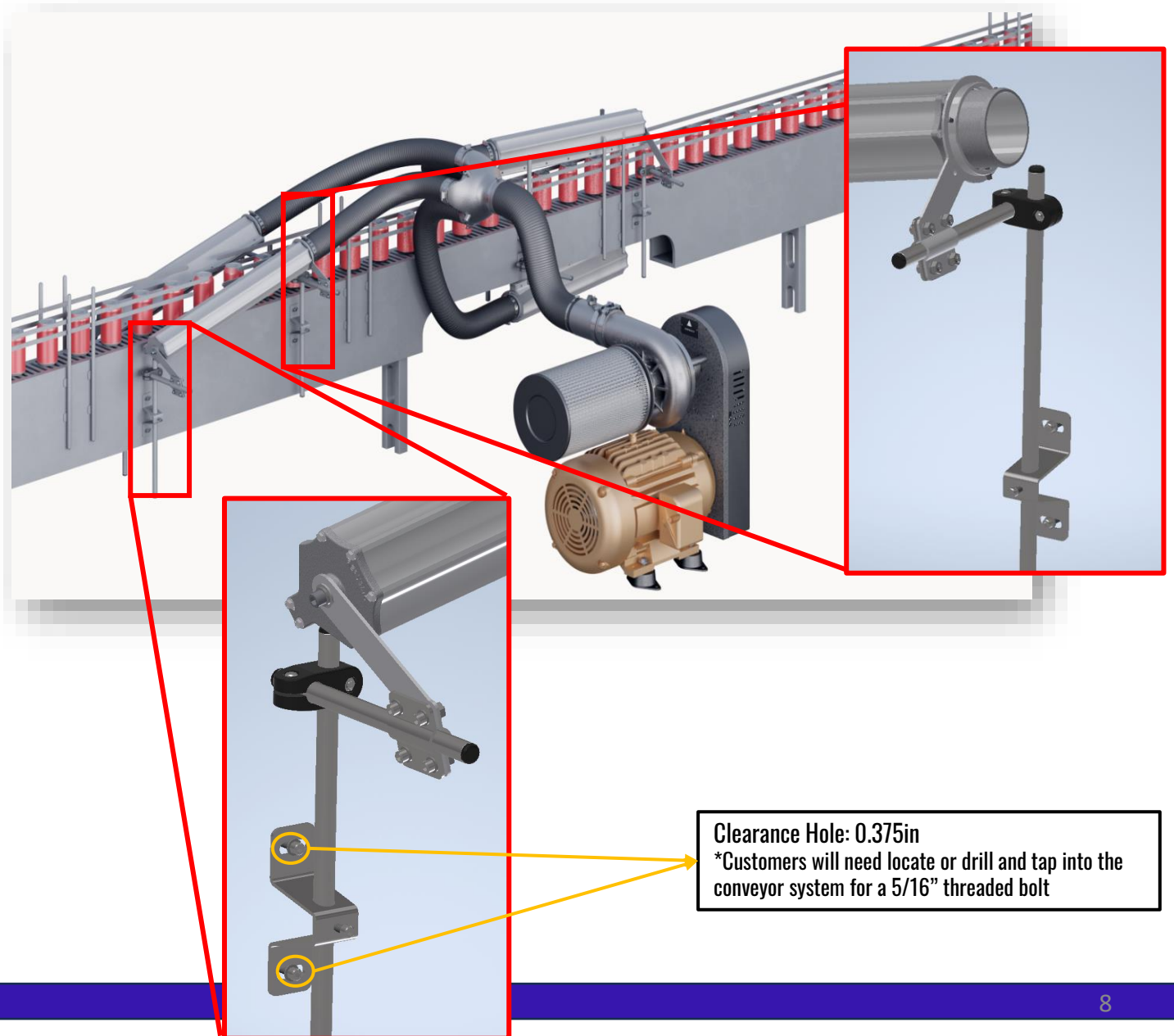

Clearance Hole: 0.375in  
\*Customers will need locate or drill and tap into the conveyor system for a 5/16" threaded bolt





# Manifold Location

4.) Identify placement location of Manifold on Air Knife system

\*It is suggested to hang the Manifold above the current conveyor system

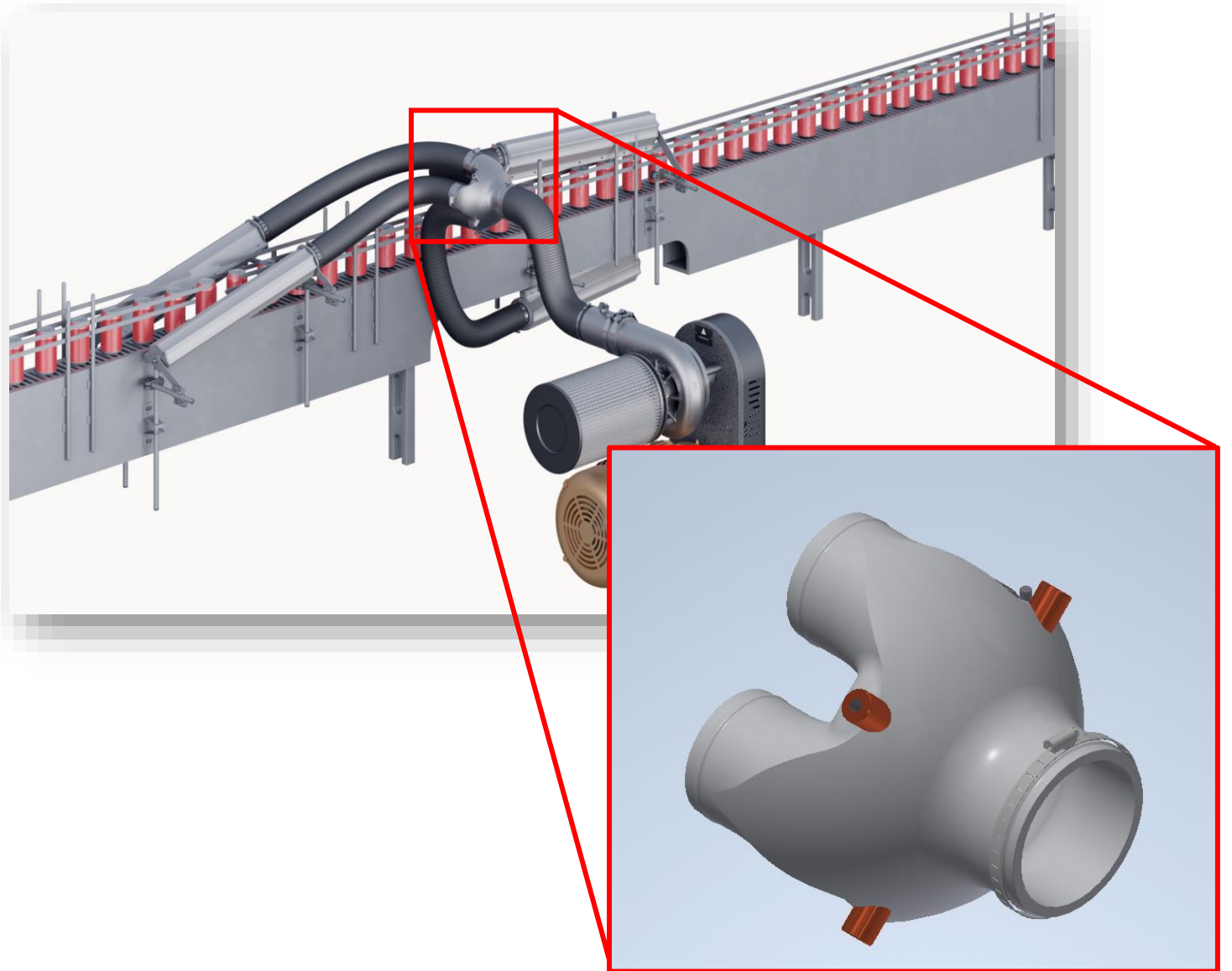



# Blower and Motor Location

## 5.) Place blower and motor assembly in desired location near the existing conveyor

- \*Ensure that the blower is installed correctly and that it is rotating in the proper direction.
- \*The blower must not be more than 10 feet from the air knives. Rigid plumbing is preferred due to the pressure loss inherent in flexible tubing. Cracks and holes in flexible tubing will allow air leaks, reducing performance and possibly over-amp the motor.
- \*The blower must be free from external vibration sources.
- \*Ensure the filter element remains clean. A contaminated filter element will decrease the life of the blower and eventually re-contaminate the dried product.
- \*Ambient temperature must not exceed 104°F to maintain motor warranty.
- \*Ensure that the belt is installed properly per the owner's manual.
- \*Ensure that the anti-backlash bolt on the belt tension arm is properly adjusted per the owner's manual. The tension spring is the only item that should hold the tension on the belt.
- \*Do not allow the blower to run at maximum RPM without a restriction in the air flow. A flow control valve, air knife, or nozzle is required.

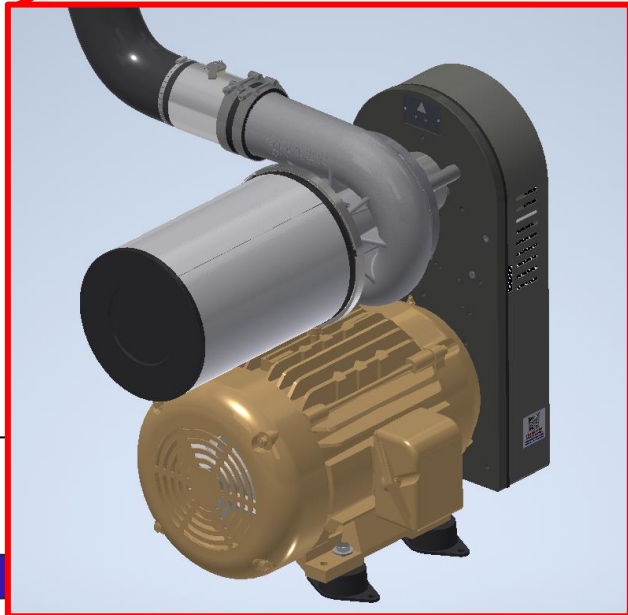
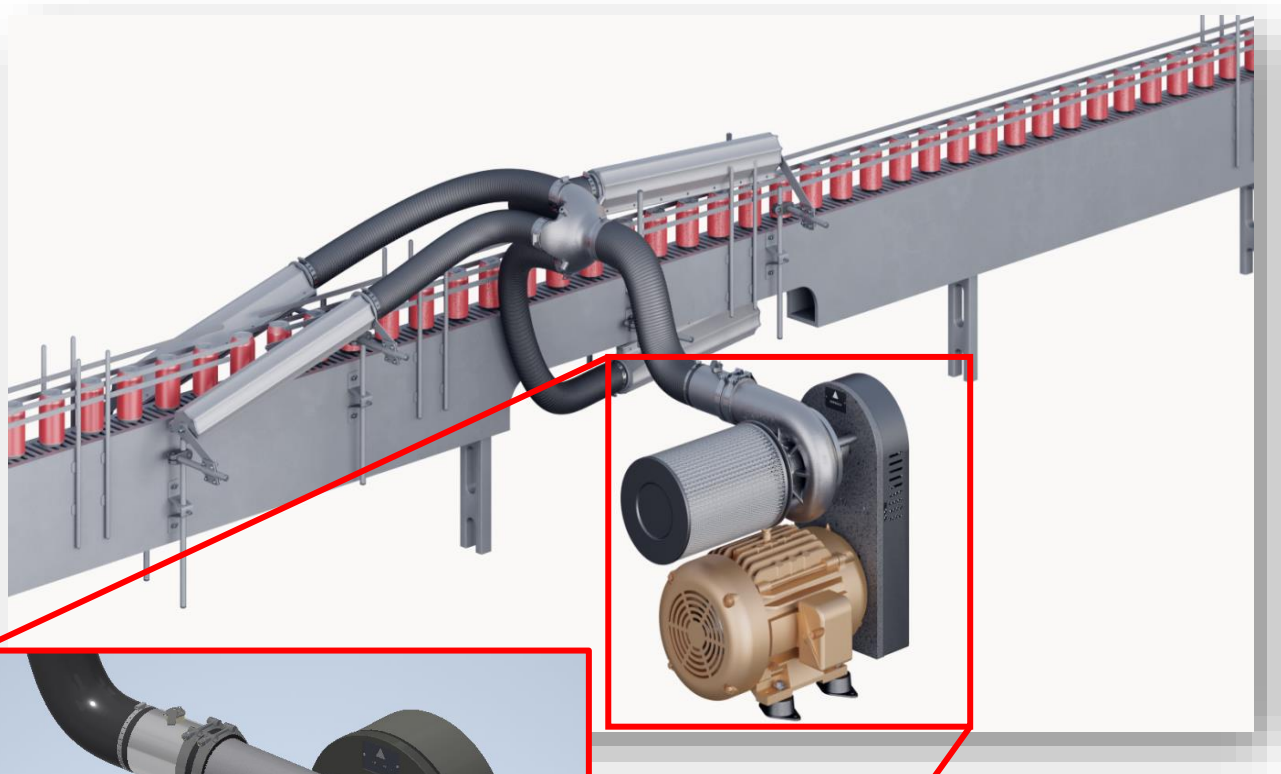



# Butterfly Valve

6.) Install provided butterfly valve to the exit side of the blower with provided Buna sleeves.

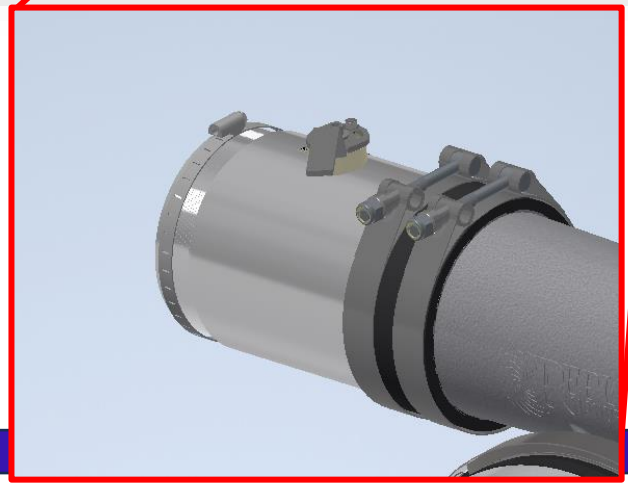
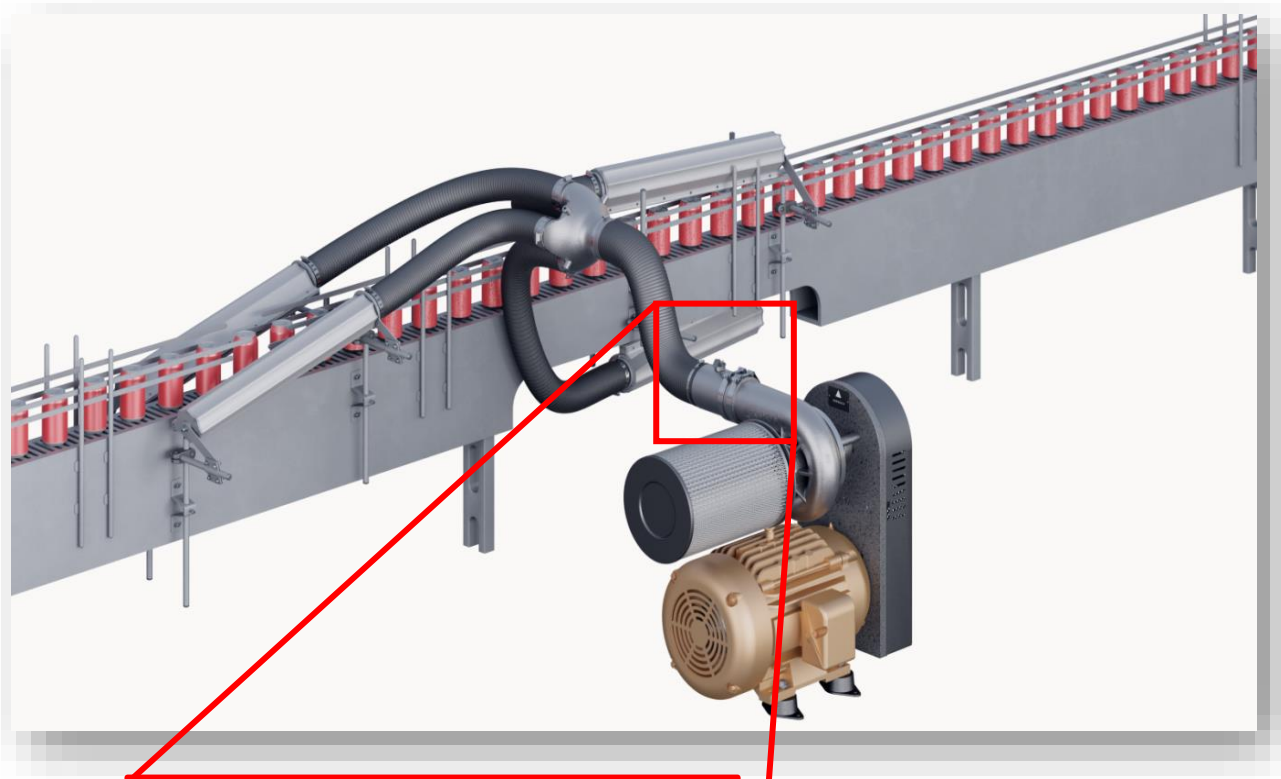



# Flex Tubing (Valve to Manifold)

7.) Measure length from blower location to desired Manifold location and cut provided flex tubing to that desired length.

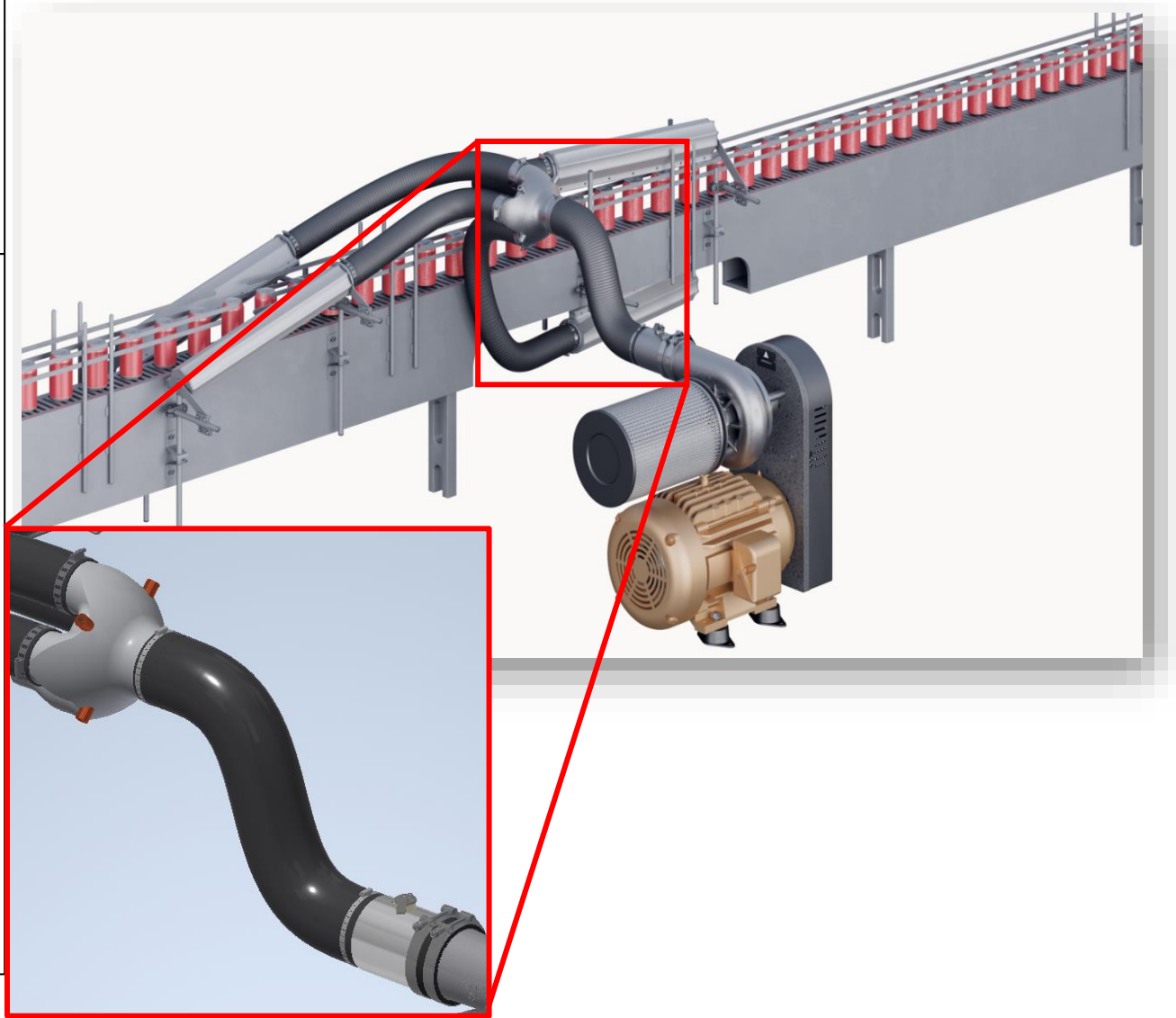



# Install Worm Gear Clamps

8.) Install newly cut flex tubing with provided worm gear clamps at the end of the butterfly valve and Manifold.

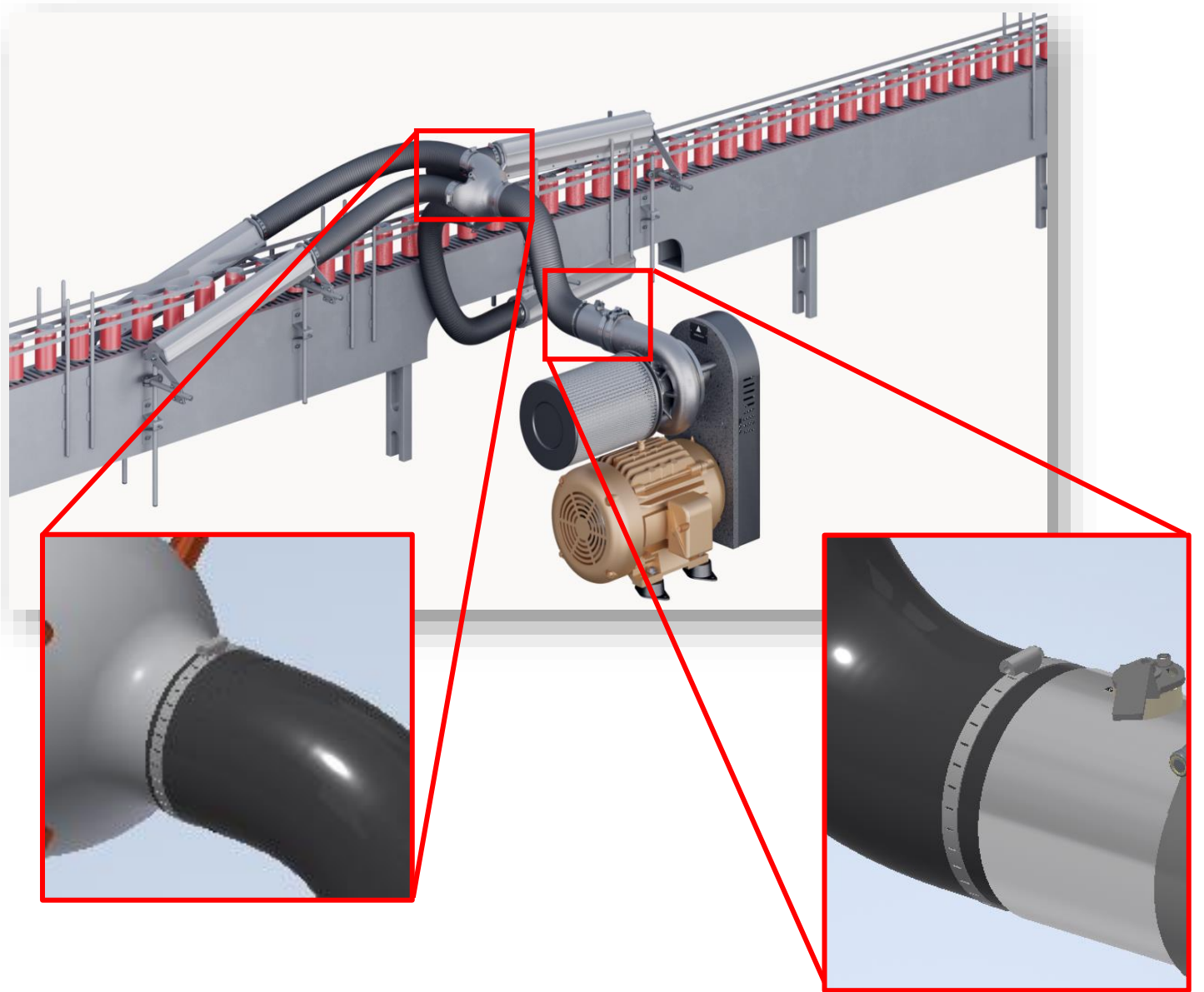





# Flex Tubing (Manifold to Air Knife)

9.) Measure length from Manifold location to desired Air Knife location and cut provided flex tubing to that desired length

\*1 per Air Knife Assembly

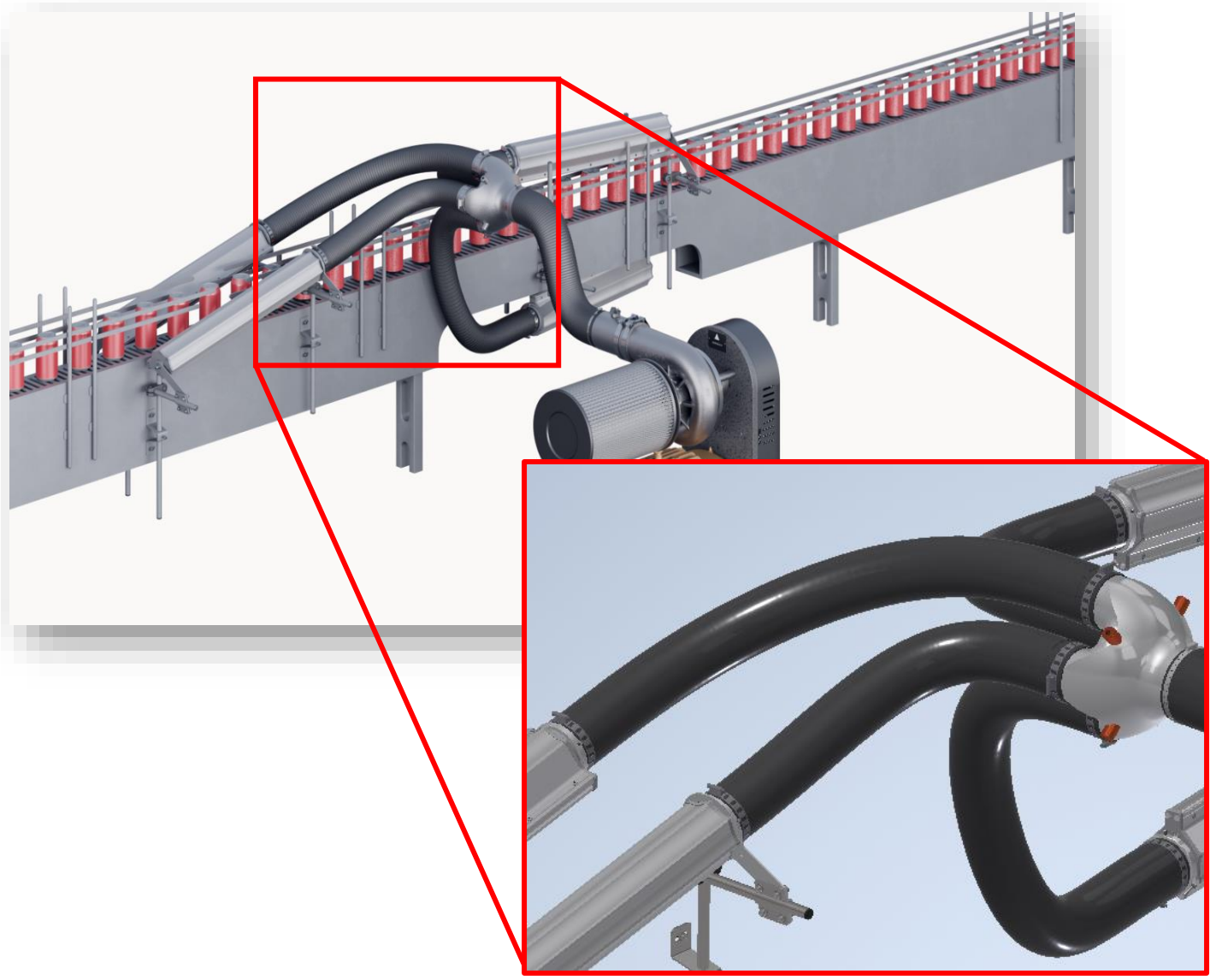





# Install Worm Gear Clamps (1)

10.) Install newly cut flex tubing with provided worm gear clamps at the end of the Manifold to the ends of the Air Knife Assemblies.

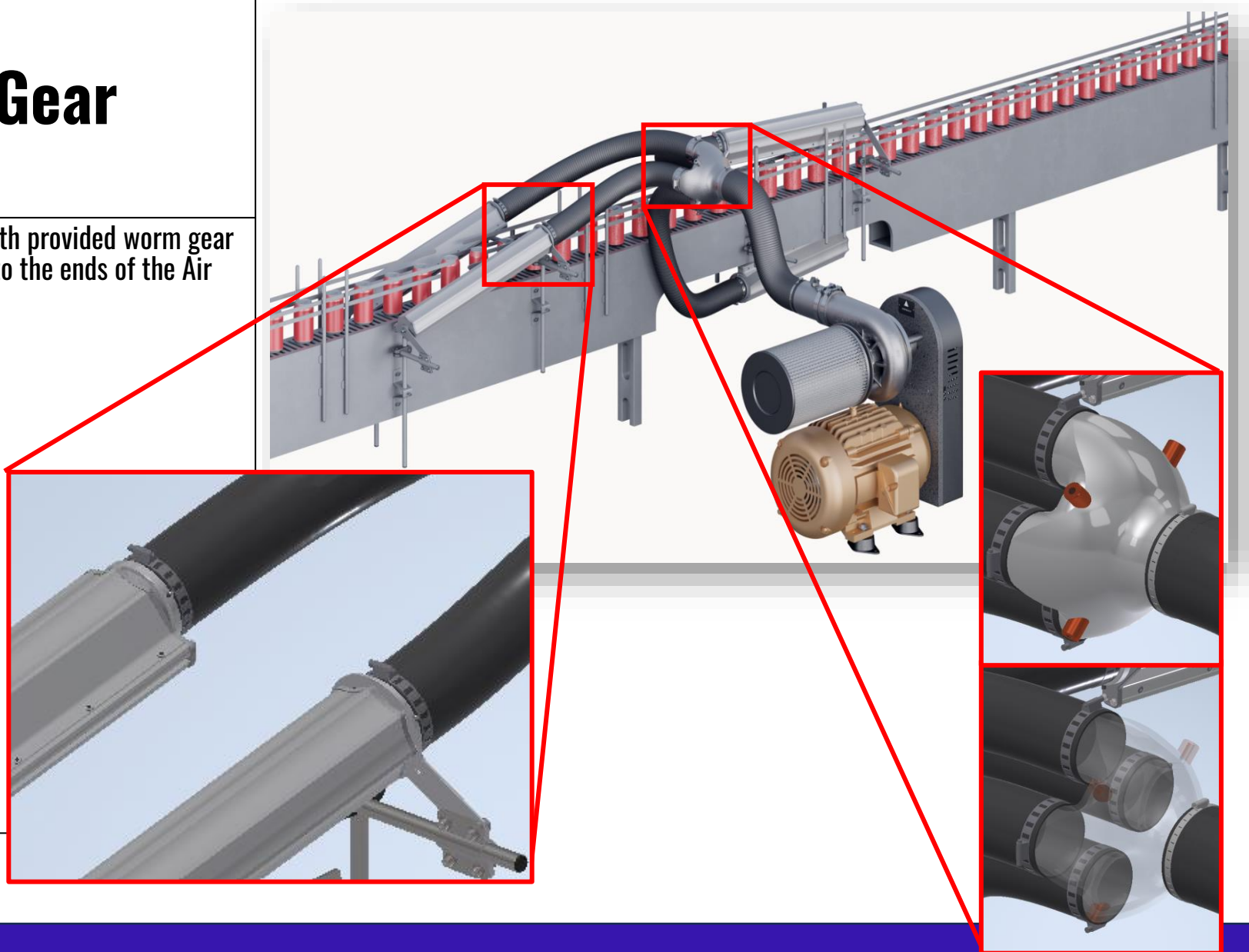



# Install Worm Gear Clamps (2)

10.) Install newly cut flex tubing with provided worm gear clamps at the end of the Manifold to the ends of the Air Knife Assemblies.

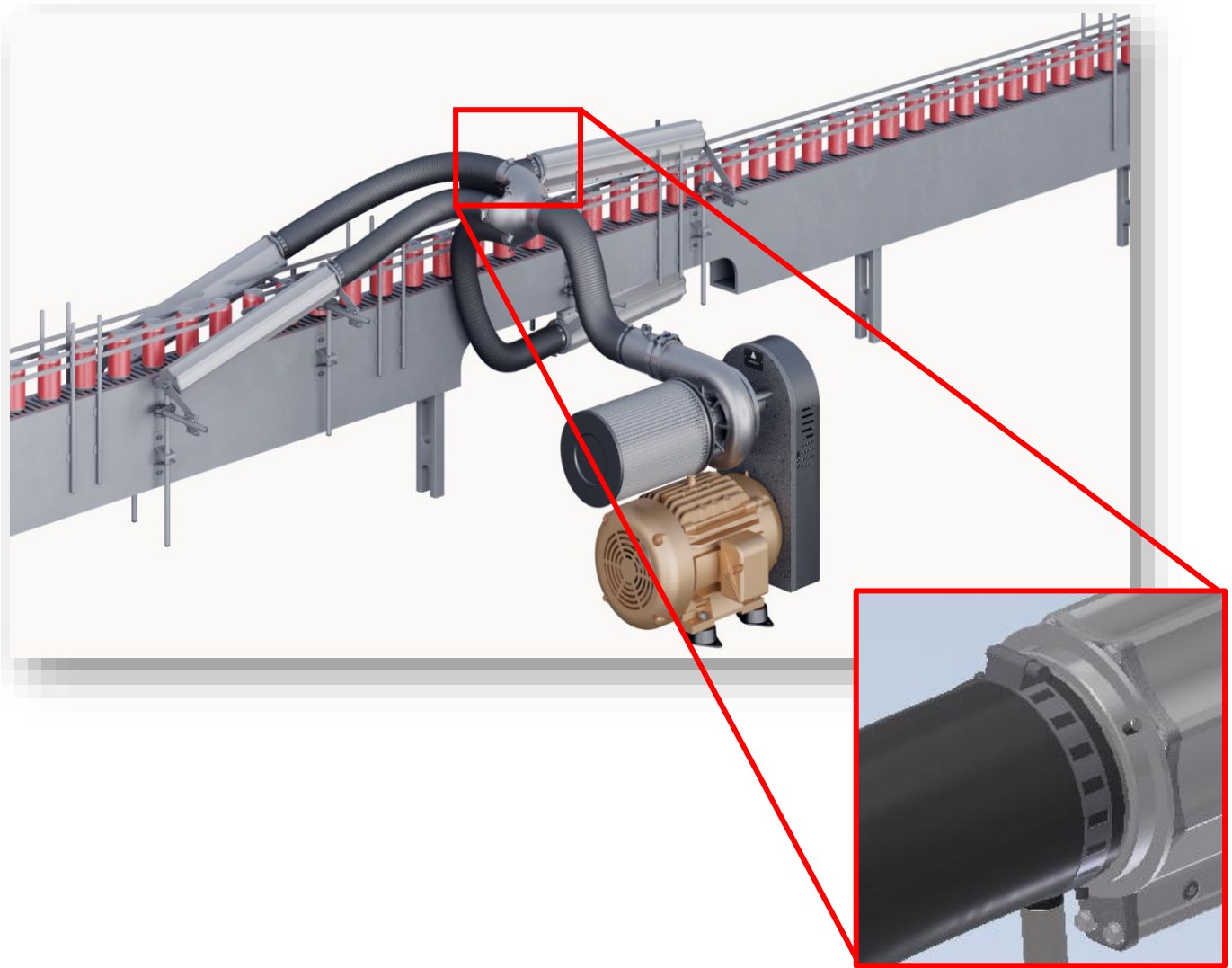



# Install Worm Gear Clamps (3)

10.) Install newly cut flex tubing with provided worm gear clamps at the end of the Manifold to the ends of the Air Knife Assemblies.

