



## FEATURES

- Single stage, direct-driven
- Continuous, contactless, oil-free operation
- Energy efficient for substantial savings
- Minimal downtime
- Air-cooled, no water required
- Simple installation
- Virtually maintenance-free
- Low noise levels
- Integrated relief valve
- Includes inlet filter with inlet silencer

## APPLICATIONS

Any oil-free application including:

- Transport
- Conveying
- Environmental
- Air sparging
- Fish farms

## OPTIONAL ACCESSORIES

- **Pre-Assembled Pressure Kit Available (KPRCP-502):** All plumbing, filtration, and gauges required for quick installation and easy maintenance.

# RCP-502

## PERFORMANCE (60HZ)

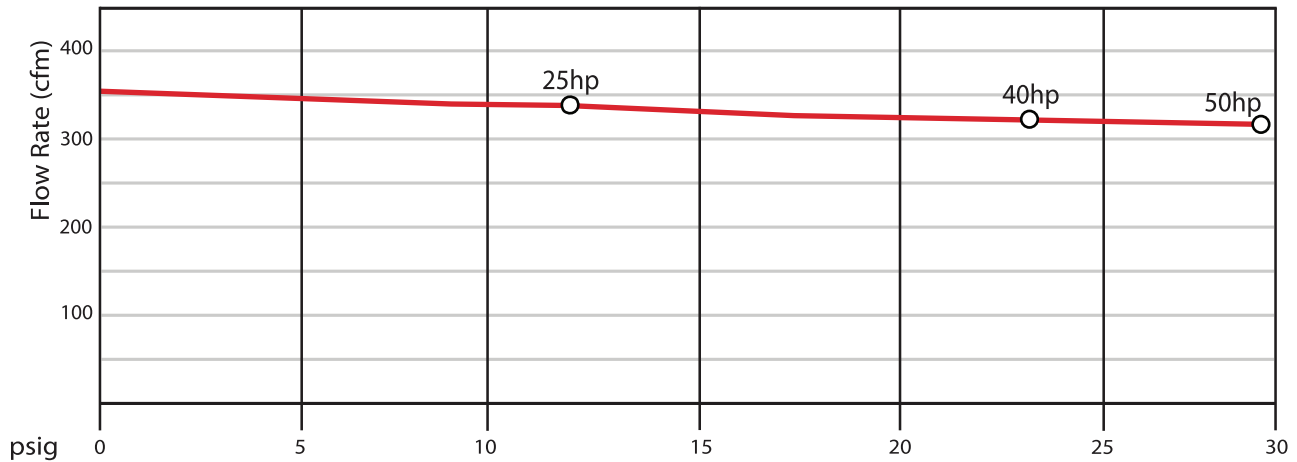

Model	Phase	Displacement (cfm)	Pressure (psig)	hp	Motor Speed (RPM)	Voltage (V)	FLA	Noise Level (dBA)	Approx. Weight (lb)	Gear Oil Amt. (L)
RCP-502-25	3	353	11.6	25.0	3450	230/460	57.8/28.9	83	765	1.8
RCP-502-40	3	353	23.2	40.0	3450	230/460	92.2/46.1	83	765	1.8
RCP-502-50	3	353	29.0	50.0	3450	230/460	113.8/56.9	83	765	1.8

All measurements are ±10%. Standard motor is Class 1 Div 2.

## APPROXIMATE DIMENSIONS

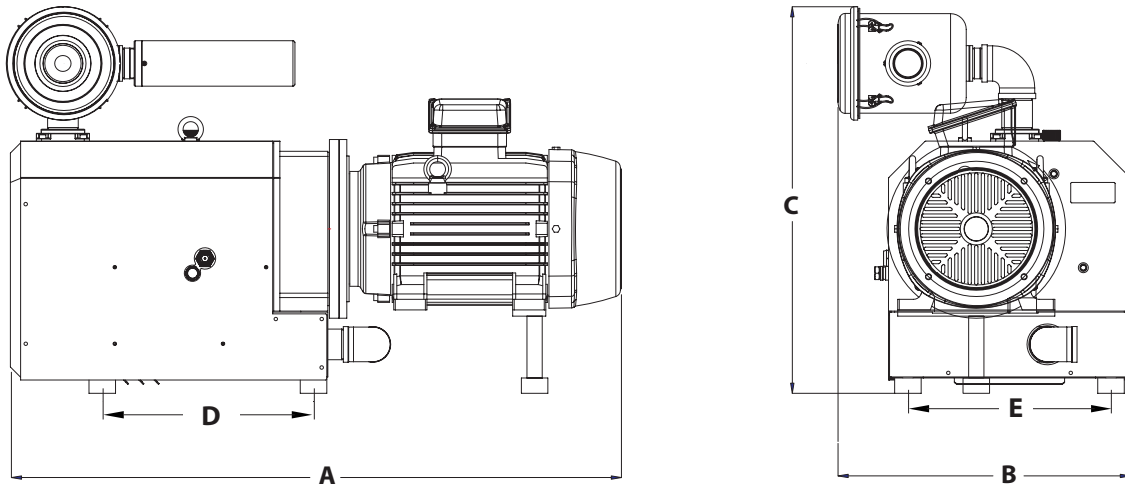

Model	A	B	C	D	E	Inlet	Outlet
RCP-502-25	50.8"	26.5"	39.5"	19.8"	18.1"	3.00" NPT	3.00" NPT
RCP-502-40	55.5"	26.5"	39.5"	19.8"	18.1"	3.00" NPT	3.00" NPT
RCP-502-50	55.5"	26.5"	39.5"	19.8"	18.1"	3.00" NPT	3.00" NPT

Please contact the factory for precise dimensions.

