



FEATURES

- Single stage, direct-driven
- Air-cooled, no water required
- Simple installation
- Low noise levels
- Compact design
- Integral exhaust filter, oil free discharge air
- Includes pressure gauge and gas ballast

APPLICATIONS

- Meat packaging
- Food processing
- Thermoforming
- Composites
- Medical
- Laboratory
- Vacuum cooling
- Robotics
- Degassing
- Autoclaves

OPTIONAL ACCESSORIES

- Pre-Assembled Vacuum Kit Available (KVRXA-250 & KVRXA-302): Includes all plumbing, filtration, check-valves, regulating valves, and gauges required for quick installation and easy maintenance.

RXA-250/302

PERFORMANCE (60HZ)

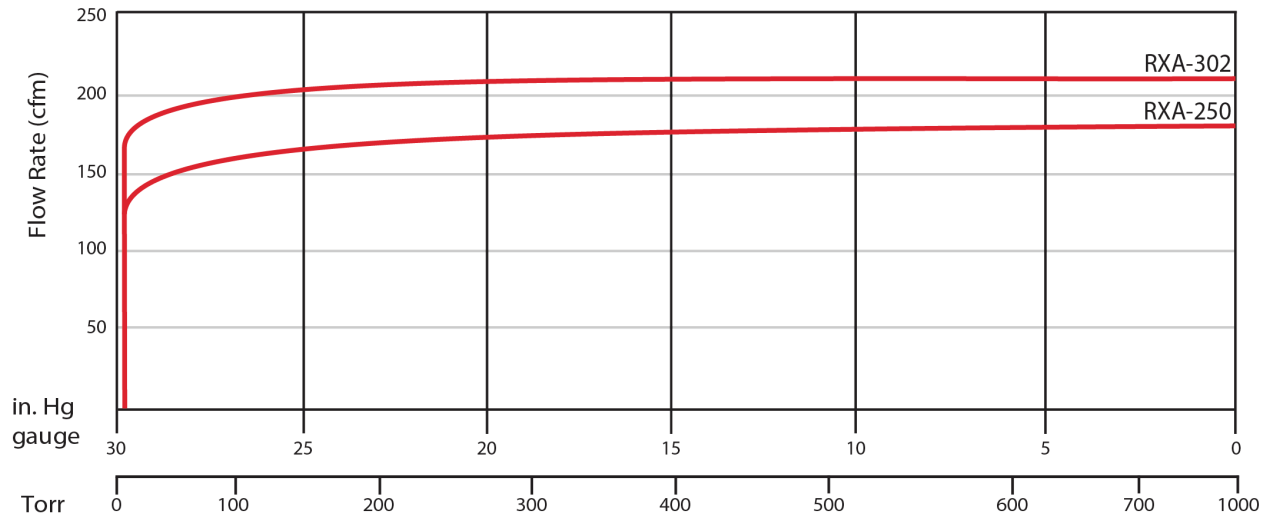

| Model | Phase | Displacement (cfm) | Ultimate Continuous Vacuum (inHg/Torr) | Motor Output | Motor Speed (RPM) | Voltage (V) | FLA | Noise Level (dBA) | Approx. Weight (lb) | Oil Capacity (L) |
|---------|-------|--------------------|--|--------------|-------------------|-------------|-----------|-------------------|---------------------|------------------|
| RXA-250 | 3 | 177 | 29.91/0.075 | 10.0 | 1800 | 230/460 | 25.0/12.5 | 77 | 406 | 8 |
| RXA-302 | 3 | 212 | 29.91/0.075 | 10.0* | 1800 | 230/460 | 25.0/12.5 | 78 | 415 | 8 |

All measurements are ±10%. Standard motor is Class 1 Div 2. *Uses a NEMA motor with a 1.25 service factor.

APPROXIMATE DIMENSIONS

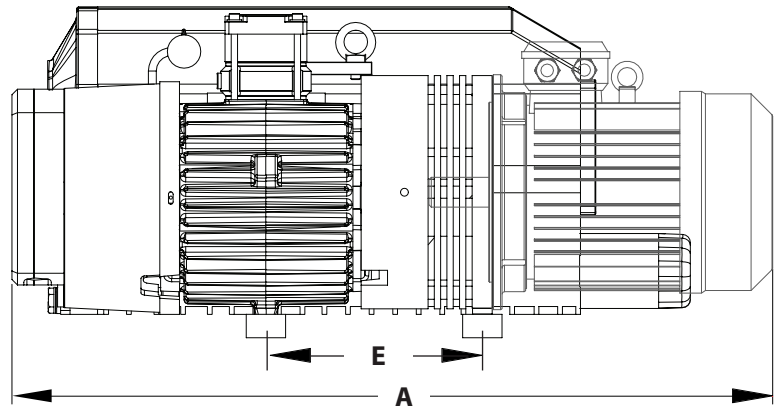
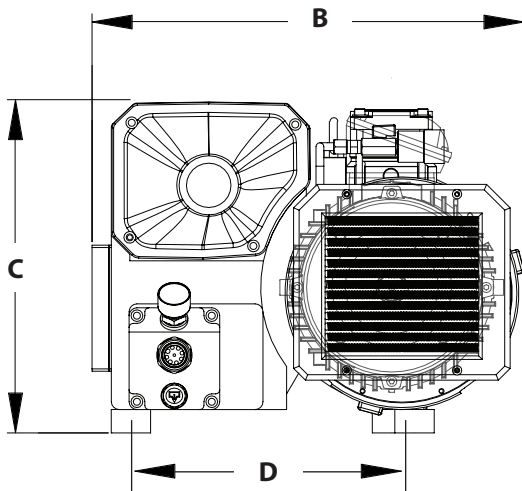

| Model | A | B | C | D | E | Inlet/Outlet |
|---------|-------|-------|-------|-------|-------|--------------|
| RXA-250 | 39.6" | 21.7" | 16.3" | 14.2" | 10.8" | 2.00" NPT |
| RXA-302 | 40.6" | 21.7" | 16.3" | 14.2" | 12.2" | 2.00" NPT |

Please contact the factory for precise dimensions.

