

FEATURES

- Single stage, direct-driven
- Air-cooled, no water required
- Simple installation
- Low noise levels
- Compact design
- Integral exhaust filter, oil free discharge air
- Includes pressure gauge and gas ballast

APPLICATIONS

- Meat packaging
- Food processing
- Thermoforming
- Composites
- Medical
- Laboratory
- Vacuum cooling
- Robotics
- Degassing
- Autoclaves

OPTIONAL ACCESSORIES

- Pre-Assembled Vacuum Kit Available (KVRXA-402, KVRXA-502 & KVRXA-632): Includes all plumbing, filtration, check-valves, regulating valves, and gauges required for quick installation and easy maintenance.

RXA-402/500/630

PERFORMANCE (60HZ)

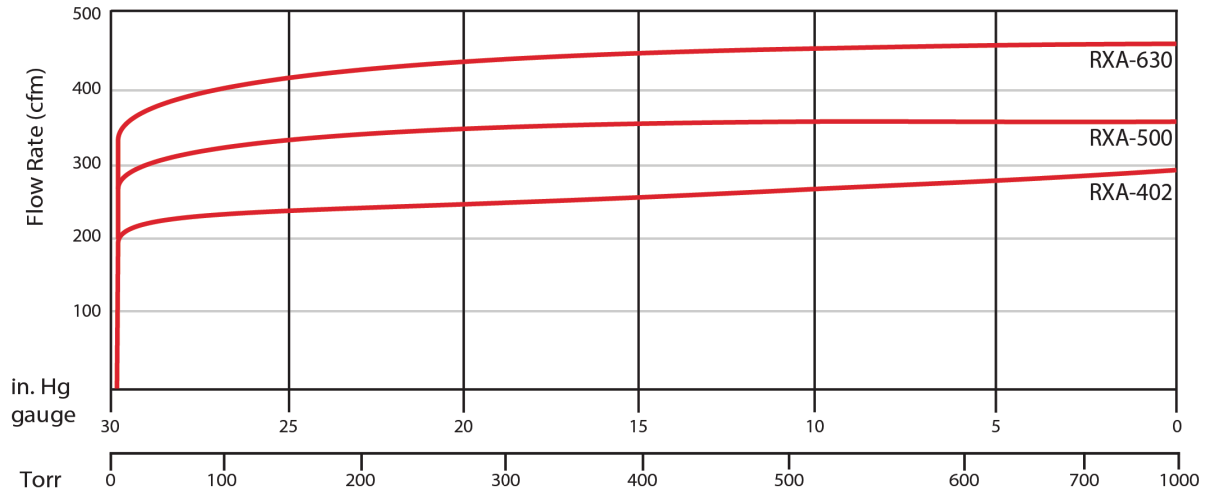

Model	Phase	Displacement (cfm)	Ultimate Continuous Vacuum (inHg/Torr)	Motor Output	Motor Speed (RPM)	Voltage (V)	FLA	Noise Level (dBA)	Approx. Weight (lb)	Oil Capacity (L)
RXA-402	3	297	29.91/0.075	20.0	1160	230/460	51.4/25.7	76	758	19
RXA-500	3	353	29.91/0.075	20.0	1160	230/460	51.4/25.7	77	758	19
RXA-630	3	459	29.91/0.075	25.0	1160	230/460	63.8/31.9	77	882	19

All measurements are ±10%. Standard motor is Class 1 Div 2.

APPROXIMATE DIMENSIONS

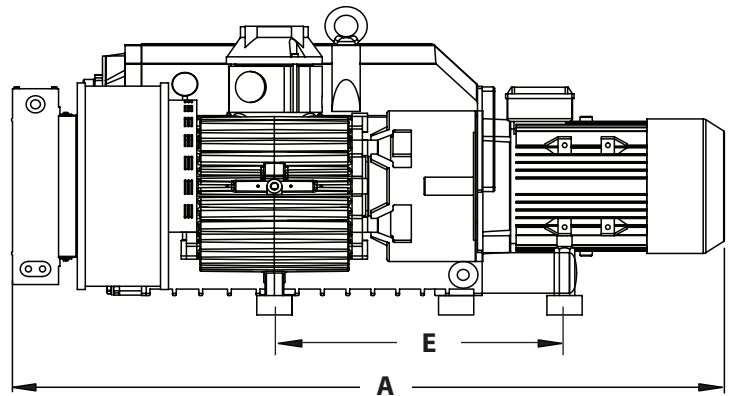
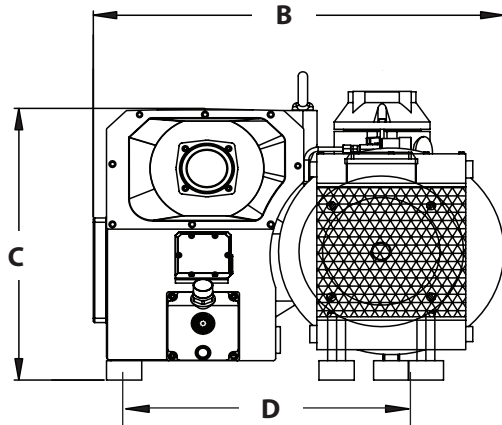

Model	A	B	C	D	E	Inlet/Outlet
RXA-402	58.5"	34.4"	26.4"	22.4"	16.4"	3.00" NPT
RXA-500	62.3"	34.4"	26.4"	22.4"	21.6"	3.00" NPT
RXA-630	68.8"	34.4"	26.4"	22.4"	25.0"	3.00" NPT

Please contact the factory for precise dimensions.

CONTACT

